

FGD-03F EVAL BOARD

Dosimeter Board and Software

sealicon

The power of small things

Target Specification. Confidential

Rev. 1.0 Page 1/11

FEATURES

- USB FGDOS® radiation sensor board
- Plug'n'play system
- Radiation sensor FGD-03F in QFN package
- Miniaturized detection system
- Data logging direct from the PC
- Dosimeters easy configuration via software
- Software with plotted data from FGD-03F

APPLICATIONS

- Radiation sensors
- Active and passive dosimetry
- Space
- Particle Physics Facilities

GENERAL DESCRIPTION

FGD-03F EVAL is an easy-to-use measuring board developed to collect data directly from an FGD-03F, containing two FGDOS® sensors.

The FGD-03F EVAL is designed to be inserted to a DLP2232H USB adapter and directly connected via USB to the PC.

FGD-03F is provided in a 32 pin QFN 5x5 mm package. Sensor configuration and access to radiation measurement results can be achieved via serial communication.

A dedicated PC software allows easy configuration and radiation data representation from FGD-03F.

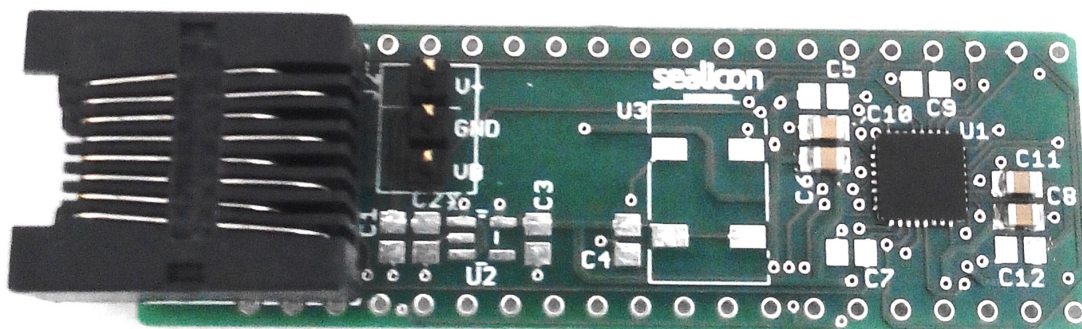

sealicon

Sealicon Microsystems is a trademark of Integrated Circuits Málaga S.L.
www.icmalaga.com Tel: +34 971518527 Email: sales@icmalaga.com

FGD-03F EVAL BOARD

Dosimeter Board and Software



The power of small things

Target Specification. Confidential

Rev. 1.0 Page 2/11

CONTENTS

FEATURES.....	1	SYSTEM.....	5
APPLICATIONS.....	1	SCHEMATIC.....	6
CONTENTS.....	2	ASSEMBLY PART LIST.....	6
ABSOLUTE MAXIMUM RATINGS.....	3	FGD-03F DRITUSB1D SOFTWARE.....	8
ELECTRICAL CHARACTERISTICS.....	3	DATASHEET REVISION HISTORY.....	10
FGD-03F EVAL USB KIT CONTENTS.....	4	DISCLAIMER.....	10
GETTING STARTED WITH FGD-02F EVAL		ORDERING INFORMATION.....	11

FGD-03F EVAL BOARD

Dosimeter Board and Software



Target Specification. Confidential

Rev. 1.0 Page 3/11

ABSOLUTE MAXIMUM RATINGS

These ratings do not imply permissible operating conditions; functional operation is not guaranteed. Exceeding these ratings may damage the device

Item No.	Symbol	Parameter	Conditions			Unit
				Min	Max	
G001	VB	Permissible Voltage at VB			20	V
G002	V()	Voltage at NIRQ, VCCD, VCC, SCK, NCS, ENWR, NSTBY, MISO, NCS, MOSI, CK	Referenced to GND		5.5	V

ELECTRICAL CHARACTERISTICS

Operating Conditions: VB=18V, VCC=4.5V .. 5.5V, VCCD = VCC, Tj=-40 .. 85 °C, Rad. source = Co60, TID=0Gy unless otherwise stated. Target Specification, limits not guaranteed.

Item No.	Symbol	Parameter	Conditions				Unit
				Min	Typ	Max	

Total Device

001	VB	Permissible Programmer Voltage at VB	Referenced to GND	15		20	V
002	I(VB)	Recharge current at VB	Recharge Disabled Recharge Enabled			1 100	μA
003	VCC	Permissible Supply Voltage at VCC	Referenced to GND	4.5		5.5	V
004	I(VCC)	Supply current at VCC	NSTBY = 1 NSTBY = 0			3 10	mA μA
005	VCCD	Permissible Supply Voltage at VCCD	Referenced to GND	4.5		5.5	V
006	I(VCCD)	Supply current at VCCD	NSTBY = 1 NSTBY = 0			2 TBD	mA
005	Vc(lo)	Clamp Voltage at VB,VCC, VCCD, MISO, NIRQ, ENWR, NCS, SCK, MOSI, CK	I() =10mA	-1.5		-0.6	V

Digital Input/Outputs

100	Isc(lo)	Short Circuit Current lo at NIRQ, MISO		-40		-4	mA
101	Isc(hi)	Short Circuit Current hi at NIRQ, MISO		4		40	mA
102	Vs(lo)	Saturation Voltage lo at NIRQ, MISO	I() =2mA	-0.4			V
103	Vs(hi)	Saturation Voltage hi at NIRQ, MISO	I() =-2mA			0.4	V
104	Vt(hi)	Input Threshold Voltage hi at ENWR, NCS, SCK, MOSI, NSTBY, CK				2	V
105	Vt(lo)	Input Threshold Voltage lo at ENWR, NCS, SCK, MOSI, NSTBY, CK		0.8			V
106	I() pd	Pull down Current at ENWR, NCS, SCK, MOSI, NSTBY, CK		1		50	μA

FGD-03F EVAL BOARD

Dosimeter Board and Software

FGD-03F EVAL USB KIT CONTENTS

Each FGD-03F EVAL Kit includes the following parts:

- 1 x FGD-03F EVAL board to be used as a sensor. It includes 1 FGD-03F sensor in QFN package.

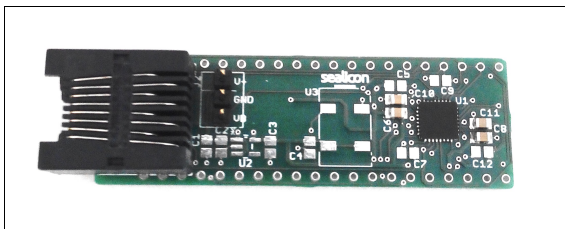

Figure 1: FGD-03F EVAL board as sensor

- 1 x FGD-03F EVAL board to be used as gateway, with no FGD-03F sensor. It includes an external oscillator to generate the Measurement Window pulse.

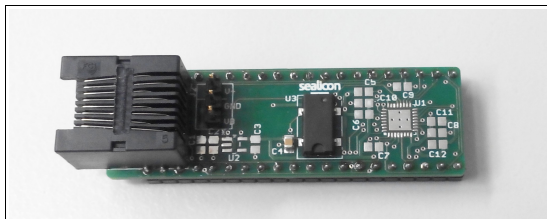

Figure 2: FGD-03F EVAL board as gateway

- 1 x DLP2232H controller to be used as USB communication interface.
- 1 x 1.5 m Ethernet cable, to connect the sensor FGD-03F EVAL board with the gateway FGD-03F EVAL board.

Board connectors

The FGD-03F EVAL board has three main connectors. The first connector is a 40-Pin socket in DIP package, where the DLP2232H usb driver can be inserted.

The second connector is an RJ45 socket with the minimum required lines (8 pins) for communicating with another FGD-03F EVAL board.

Finally, a three-pin connector (V+, VB and GND) is provided. The board can be supplied either through the DLP2232H module from the USB connector or externally through pins V+ and GND. VB pin can be used to recharge externally the sensor, although the the default configuration in FGD-03F EVAL board is to use the internal charge pump.

FGD-03F EVAL BOARD

Dosimeter Board and Software

GETTING STARTED WITH FGD-02F EVAL SYSTEM

The FGD-03F EVAL system requires a Windows based system. To start communication with the FGD-03F sensors the following basic steps should be followed:

1. Install the DLP2232H interface drivers provided in the USB pen drive in the kit.
2. The DLP2232H module must be configured with jumpers JP1 to JP3 as it is shown in Figure 3. JP1 plugged, JP2 plugged to the right and JP3 unplugged.

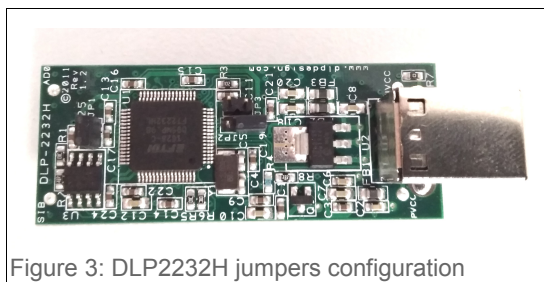

Figure 3: DLP2232H jumpers configuration

3. Insert the FGD-03F EVAL board as gateway, with no FGD-03F sensors, onto the DLP2232H driver, as shown in Figure 4.

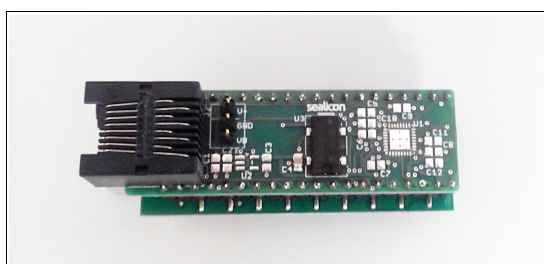

Figure 4: FGD-03F EVAL as gateway inserted on DLP2232H driver

4. Connect the FGD-03F EVAL board as sensor with the FGD-02F EVAL board as gateway with the Ethernet cable provided.

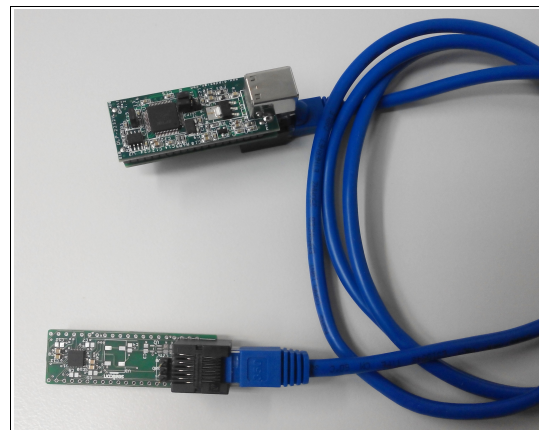

Figure 5: Final setup

5. Connect the PC to the DLP2232H driver board with the USB cable provided. Figure 5 shows how this final setup looks like.
6. Execute in the computer the software provided with the kit. See FGD-03F DRITUSB1D software chapter for further information.

FGD-03F EVAL BOARD

Dosimeter Board and Software



The power of small things

Target Specification. Confidential

Rev. 1.0 Page 6/11

SCHEMATIC

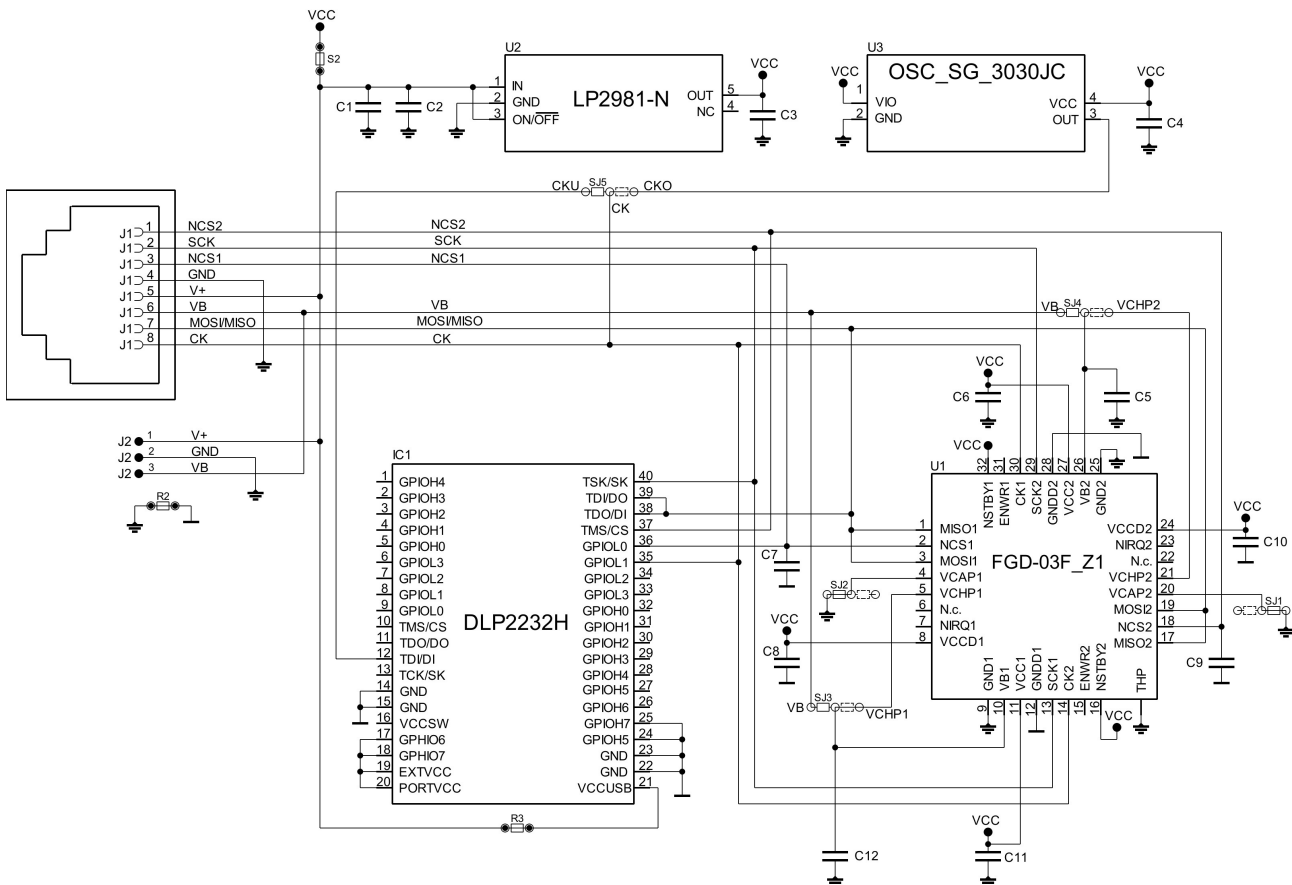

ASSEMBLY PART LIST

Device	Sensor Board	Gateway Board	Comment
C1...3, C5, C7, C9	Not soldered	Not soldered	X7R 10V, tolerance 10%
C4	Not soldered	100 nF	X7R 10V, tolerance 10%
C6, C8, C10, C11	100 nF	Not soldered	X7R 10V, tolerance 10%
IC1	Not soldered	DLP2232H	USB adapter chip
J1	RJ45	RJ45	Ethernet input connector
J2	WSL3	WSL3	3 pin connector male
SJ1, SJ2	Solder Jumper	Solder Jumper	Connected to GND
SJ3, SJ4	Solder Jumper	Solder Jumper	Connected to VCHP1,2
SJ5	Solder Jumper	Solder Jumper	Connected to oscillator CKO



FGD-03F EVAL BOARD

Dosimeter Board and Software



Target Specification. Confidential

Rev. 1.0 Page 7/11

Device	Sensor Board	Gateway Board	Comment
U1	FGD-03F_Z1	Not soldered	Floating gate dosimeter
U2	Not soldered	Not soldered	Micropower 5V LDO regulator
U3	Not soldered	OSC_SG_3030JC	32.768 kHz oscillator

FGD-03F EVAL BOARD

Dosimeter Board and Software



Target Specification. Confidential

Rev. 1.0 Page 8/11

FGD-03F DRITUSB1D SOFTWARE

The software to communicate with FGD-03F EVAL board, together with the DLP2232H drivers, are provided in the USB stick included in the demoboard kit.

A graphical user interface (GUI) is included in the

software to allow easier system configuration and data handling. Figure 6 shows the default view of the GUI. The application contains the following sections: *Dashboard* panel, *FGD-03F configurations* panel, *Start Reading* button and *Reconnect* button.



Figure 6. Default view of the GUI for controlling FGD-03F_Z1 sensors with Dashboard panel selected

Reconnect button: It gives information about the connection between the computer and the usb driver. If red, no connection is available. When it is green, the connection between devices is established.

Start Reading button: When pressed, all data from both sensors in FGD-03F chip are read and shown on screen.

FGD-03F configuration panel: It allows an advanced configuration of FGD-03F working bits for

each sensor. With the default configuration, the system can be controlled using only the *Dashboard panel*. For detailed information regarding the function of each configuration bit, please refer to FGD-03F Datasheet.

Dashboard panel: The dashboard panel is divided into several sections: *Sensor readout*, *Sensor Recharge control*, *Apply config*, *Plot Windows*, *File logging* and *System settings*.

File logging: If *Log to File* checkbox is checked, a

FGD-03F EVAL BOARD

Dosimeter Board and Software



The power of small things

Target Specification. Confidential

Rev. 1.0 Page 9/11

file is generated with all measured data from both sensors. The file name has the following structure:

FGD-03F_SN0_SN1

where SN0 is the serial Number of sensor 0 and SN1 is the one of sensor 1.

Logging action is only carried out as long as a Read action is active. Data obtained with consecutive Read processes are stored in the same file.

System settings: This section allows configuring the logging rate. It is important to allow a complete sensor and reference read action between two consecutive logs. By checking *Auto*, this is ensured automatically.

System clock frequency and Gate time can be configured here. Each field will be only writeable if the corresponding measurement window mode is selected in the Recharge control section.

Sensor Readout: Each sensor has a Sensor readout section, where the values the Sensor, the Reference, the internal temperature and the serial number are shown. Sensor and Reference numerical values can be shown in green, black or red colours. Green values correspond to new measured values; values in black refer to old values, while red values are shown when an overflow has occurred.

The number of recharges carried out is also available. This number is volatile and it is cleared once the sensor is powered down. An indicator shows in green if the sensor is sensing or else in red if it is being recharged.

The bar on the right side shows the value of the sensor between the threshold (bar minimum) and target (bar maximum) values.

Recharge control: Each sensor has a recharge control section. It allows configuring the recharging action, including threshold, target and charge mode. The type of measurement window can also be selected here, as well as the Sensitivity Mode.

FGD-03F EVAL board as gateway includes an external oscillator and therefore only allows Counter Window Mode. If Gating is selected, no valid data will be read.

Apply config: When recharging the sensor, it is recommended to set sensor value as close as possible to the reference value. If Auto target is selected, the software automatically configures the recharge target values to a value close to the reference.

Plot windows: This section allows plotting the read values of the sensor and reference, as it is shown in Figure 7.

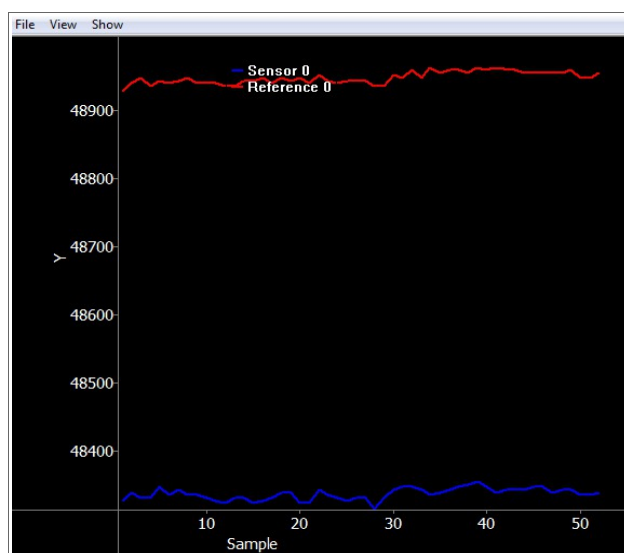

Figure 7. Plotting views with sensor and reference values for each sensor.

FGD-03F EVAL BOARD

Dosimeter Board and Software



Target Specification. Confidential

Rev. 1.0 Page 10/11

DATASHEET REVISION HISTORY

Rel.	Rel. Date	Chapter	Modification	Page
A1.0	30/07/2019		Initial Release	

DISCLAIMER

The data presented in this document is for informational purposes for engineering samples, which have not yet been qualified for production. It shall in no event be regarded as a guarantee of final specifications or characteristics. Any warranty or license of this product shall be specified and governed by the terms of a separate purchase agreement. Sealicon Microsystems conveys no patent, copyright, mask work right or other trade mark right to this product. Sealicon Microsystems assumes no liability for any patent and/or other trade mark rights of a third party resulting from processing or handling of the product an/or any other use of the product.

Sealicon Microsystems products are not designed for and must not be used in connection with any applications where the failure of such products would reasonably be expected to result in significant personal injury or death (Safety-Critical applications) without Sealicon Microsystems specific written consent. Safety-critical applications include, without limitation, life support devices and systems. Sealicon Microsystems products are not designed nor intended for use in military or aerospace applications or environments or in automotive applications unless specifically designated for such use by Sealicon Microsystems.

Sealicon Microsystems reserves the right to make changes in these specifications and features shown herein to improve reliability, function and design, or discontinue of this product, at any time without notice or obligation.

FGD-03F EVAL BOARD

Dosimeter Board and Software



The power of small things

Target Specification. Confidential

Rev. 1.0 Page 11/11

ORDERING INFORMATION

Product	Description
FGD-03_Z1	FGD-03_Z1 sensor, non-characterized, QFN32
FGD-03F_Z1 TC	FGD-03_Z1 sensor, temperature characterized QFN32
FGD-03F_Z1 RTC	FGD-03_Z1 sensor, radiation and temperature characterized, QFN32
FGD-03F EVAL RTC	Evaluation board with FGD-03_Z1 sensor, radiation and temperature characterized

Sealicon Microsystems is a trademark of Integrated Circuits Málaga S.L.

For technical support, information about prices and terms of delivery, and purchase orders please contact:

iC-Málaga s.l.
Virgen del Refugio, 5, 1ºB
07340 Alaró (Illes Balears)
Spain

Tel.: +34 971 528 527
Fax.: +34 971 518 312
Web: www.icmalaga.com
E-Mail: sales@icmalaga.com